

TODAY SLEEPER

DISASSEMBLY INSTRUCTIONS

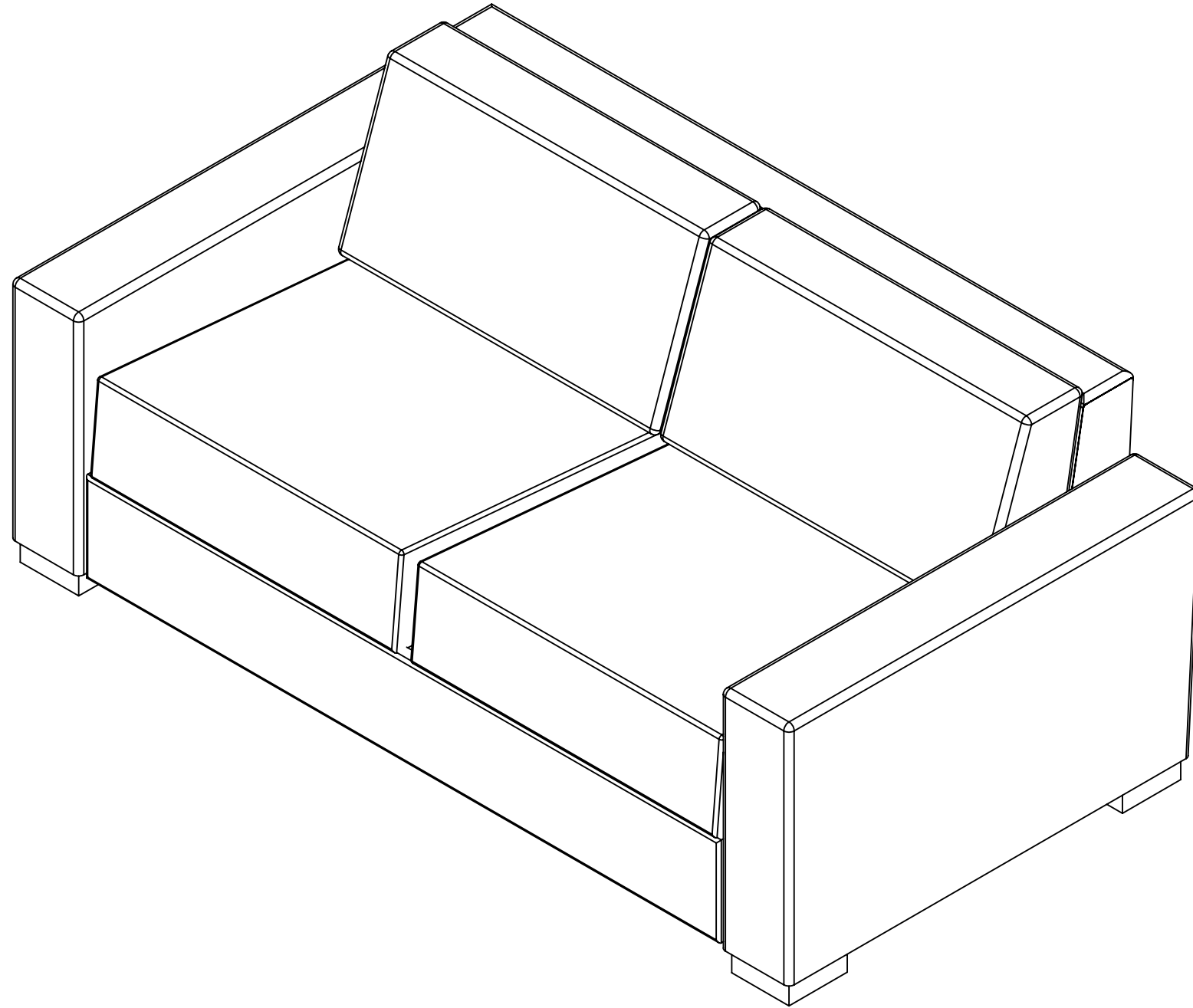

AMERICAN
LEATHER®

STYLE IN MOTION GUIDE:

- SHEET 3: HOW TO REMOVE BACK.
- SHEET 4: HOW TO REMOVE ARMS.
- SHEET 5: EXPLODED VIEW.

HOW TO REMOVE BACK SECTION:

STEP 1:
OPEN FRONT BED SECTIONS.

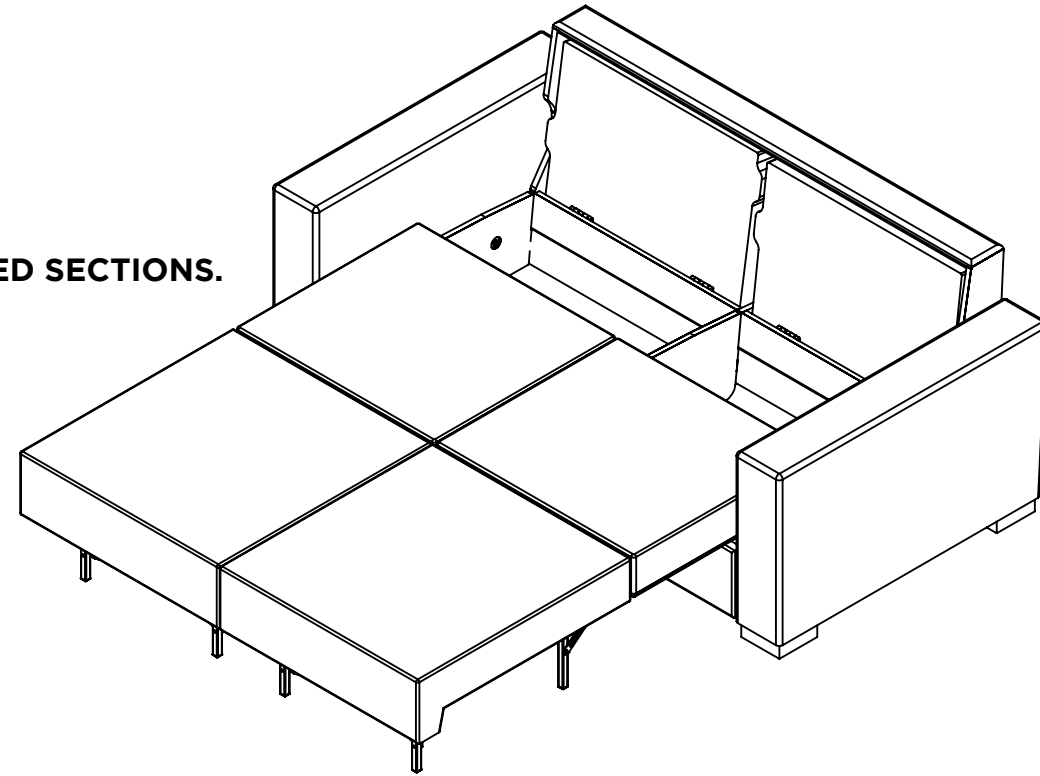

STEP 2:
REMOVE 5/16" BOLT USING A 1/2" DRIVER.

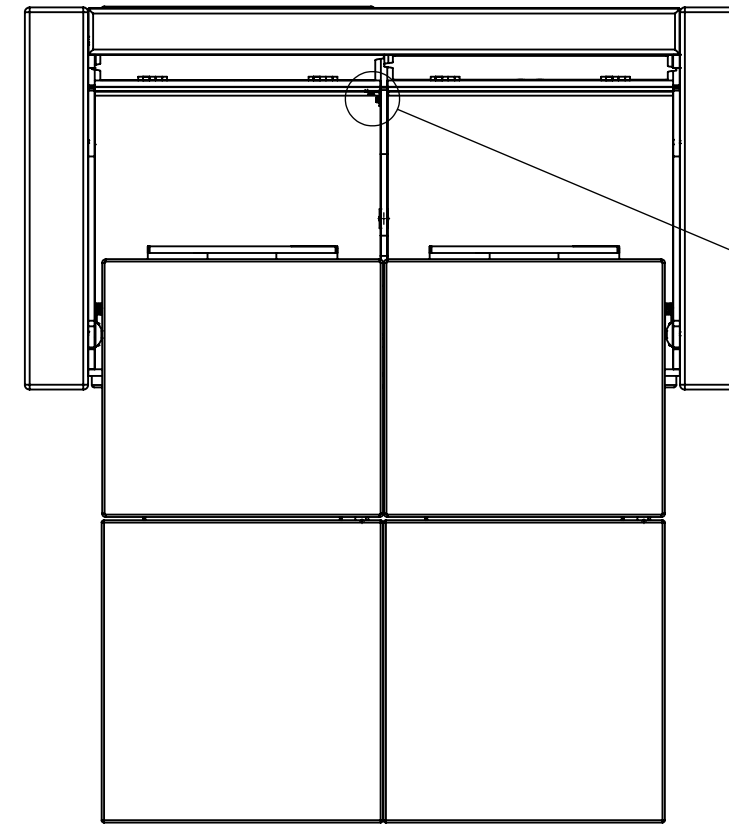

TOP VIEW
LOOKING DOWN

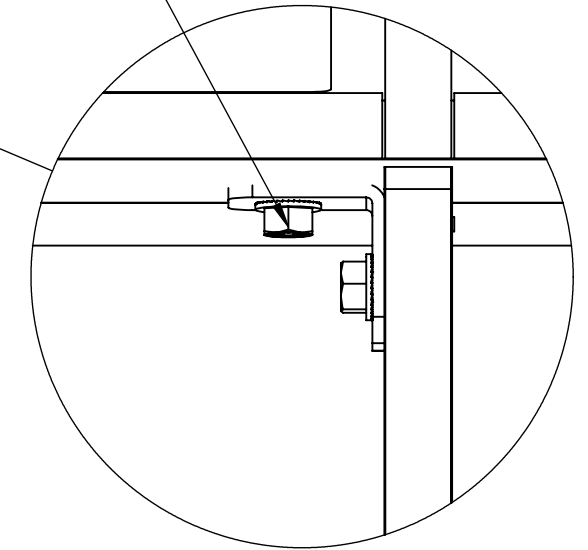

DETAIL A
SCALE 1 : 2

STEP 3:
FOLD BACKS DOWN.

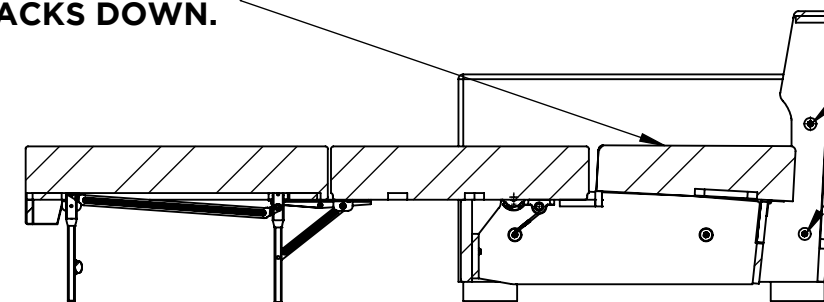

SIDE VIEW

STEP 4:
REMOVE 5/16" BOLTS
USING A 1/2" DRIVER.
BOTH SIDES.

HOW TO REMOVE ARMS:

STEP 1:
ROLL ARMS FORWARD.

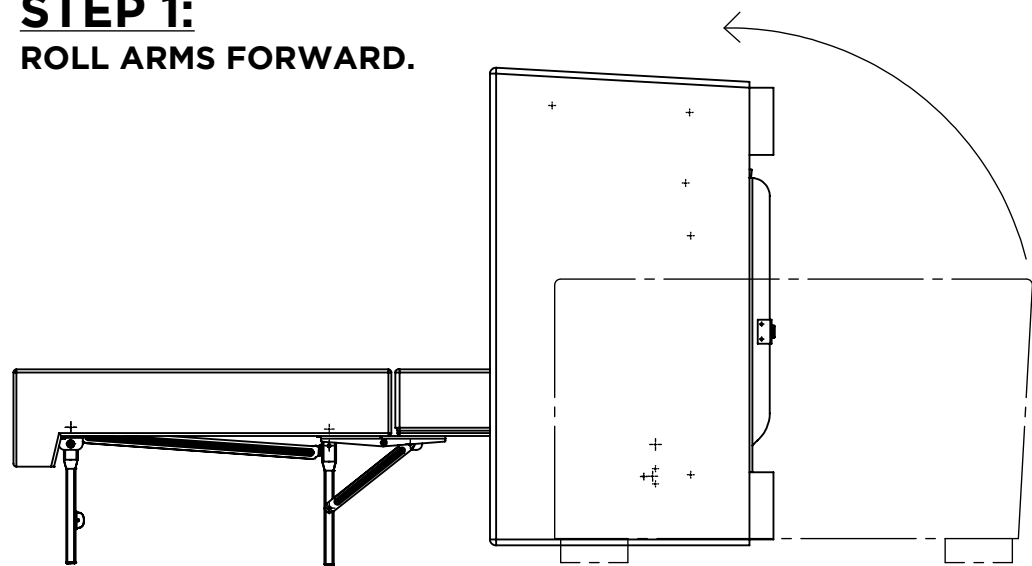

STEP 4:
ROLL BOX DOWN TO FLOOR.

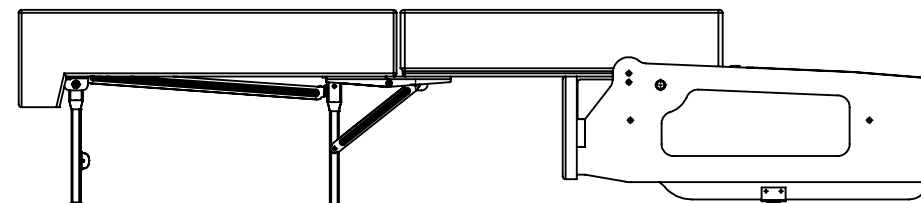

STEP 2:
REMOVE TWO 5/16" BOLTS
USING 1/2" DRIVER.

STEP 3:
REPEAT FOR OPPOSITE SIDE.

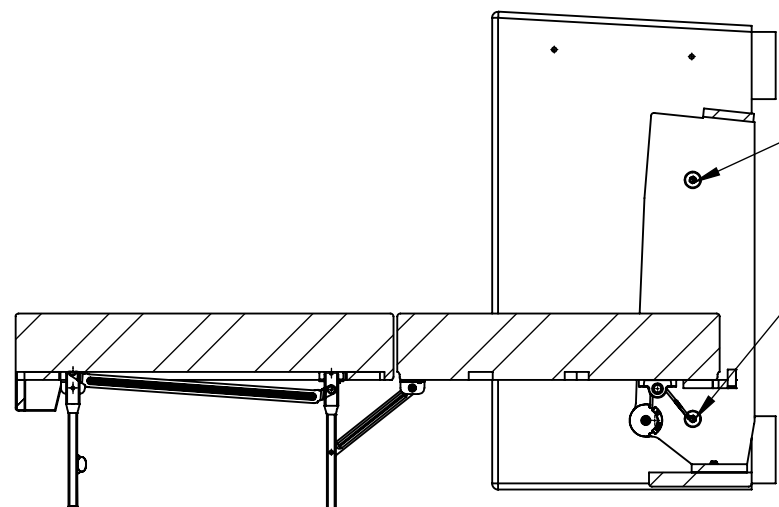

STEP 5:
CLOSE BED SECTIONS AND PUT SUPPLIED SEAT STRAPS
ON BEFORE MOVING.

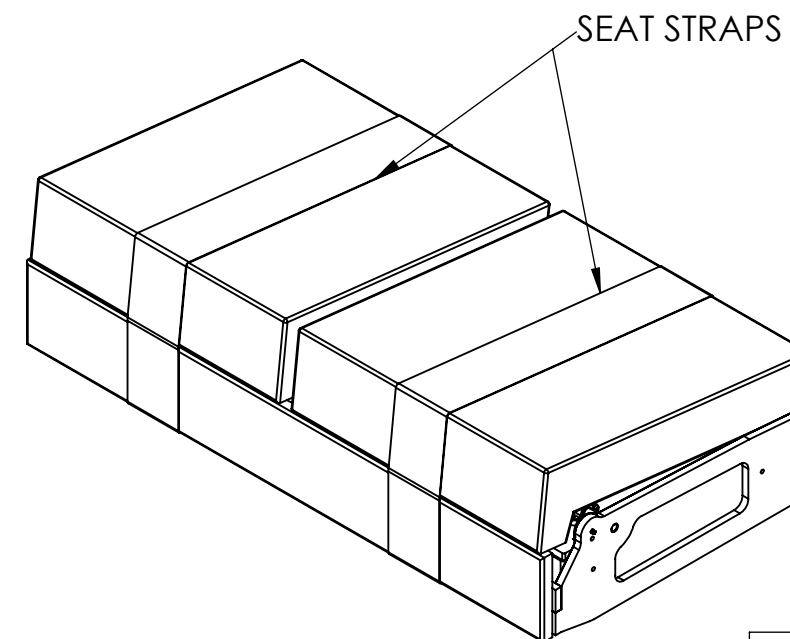

TODAY SLEEPER EXPLODED VIEW:

